

XENOWORKS™ BRI ANALOG MICROINJECTOR OPERATION MANUAL

REV. 4.00 (20100521)



SUTTER INSTRUMENT

ONE DIGITAL DRIVE
NOVATO, CA 94949

VOICE: 415-883-0128 WEB: WWW.SUTTER.COM
FAX: 415-883-0572 EMAIL: INFO@SUTTER.COM



Copyright © 2008-2010 Sutter Instrument Company. All Rights Reserved.

No part of this manual may be reproduced, stored in a retrieval system, or transmitted, in any form or by any means, electronic, mechanical, photocopying, microfilming, recording, or otherwise, without written permission from Sutter Instrument Company.

XenoWorks is a trademark of Sutter Instrument Company.

DISCLAIMER

- The **XenoWorks BRI** Analog Microinjector should only be used in a laboratory environment for use on animal tissues. It is not intended for use, nor should be used, in human experimentation, or applied to humans in any way. This is not a medical device.
- Do not open or attempt to repair the instrument without expressed and explicit instructions from Sutter Instrument Company.
- Do not allow unauthorized and or untrained operatives to use this device.
- Any misuse will be the sole responsibility of the user/owner and Sutter Instruments assumes no implied or inferred liability for direct or consequential damages from this instrument if it is operated or used in any way other than for which it is designed.

PRECAUTIONS AND GENERAL SAFETY INFORMATION

- Please read this manual carefully before operating the instrument.
- Do not operate if there is any obvious damage to any part of the instrument.
- As with all microinjection devices, sharp micropipettes can fly out of their holder unexpectedly. Always take precautions to prevent this from happening. Never loosen the micropipette holder chuck when the tubing is pressurized, and never point micropipettes at yourself or others. Always wear safety glasses when using sharp glass micropipettes with pressure microinjectors.
- Use this instrument only for microinjection purposes in conjunction with the procedures and guidelines in this manual.
- This instrument is designed for use with capillary glass micropipettes with an outer diameter of 1mm. Adapters for other capillary diameters are available upon request.
- Please retain the original packaging for future transport of the instrument.
- Some applications, such as piezo-impact microinjection call for the use of mercury in the micropipette tip. The use of any hazardous materials with any XenoWorks instrument is not recommended and under taken at the users' own risk.
- This instrument has moving parts that may create pinch points. Take extra care not to operate the instrument when there is a danger of crushing fingers or cables.
- Always transport the instrument in its original foam packaging.
- This instrument contains no user-serviceable components. This instrument should be serviced and repaired only by Sutter Instrument or an authorized Sutter Instrument servicing agent.
- Operate this instrument only according to the instructions included in this manual.
- This device is intended only for research purposes.
- Sutter Instrument reserves the right to change specifications without prior notice.
- For technical assistance, please contact your local Sutter Instrument dealer or (in the U.S.) call 1-415-883-0128. You may also E-mail your queries to info@sutter.com.

(This page intentionally left blank.)

TABLE OF CONTENTS

Disclaimer.....	iii
Precautions and General Safety Information.....	iii
1. General Information	1
1.1 Packing List.....	1
1.2 Controls and Features.....	2
1.2.1 Syringe Clamp	2
1.2.2 Plunger Clamp Screw	2
1.2.3 Sliding Block	2
1.2.4 Coarse and Fine Controls.....	2
1.2.5 Angle Adjustment.....	3
1.3 Micropipette Holder.....	3
2. Assembly and Installation	5
2.1 Installation and Assembly.....	5
3. Operating Instructions	9
3.1 General.....	9
3.2 Fitting a Micropipette.....	9
4. Maintenance.....	11
4.1 Fitting New O-rings.....	11
4.2 Troubleshooting.....	11
Appendix A. Limited Warranty	13
Appendix B. Accessories and Spare Parts.....	15
Appendix C. Technical Specifications	17
Index	19

TABLE OF FIGURES

Figure 1-1. Components of the XenoWorks analog microinjector.	1
Figure 1-2. Analog microinjector controls and features.	2
Figure 1-3. Micropipette holder components.....	3
Figure 2-1. Attaching the tubing to the injector.	5
Figure 2-2. Connecting the tubing to the tip of the syringe.....	6
Figure 2-3. Drawing hydraulic fluid into the syringe.	7
Figure 2-4. Assembling the pipette holder.....	8

(This page intentionally left blank.)

1. GENERAL INFORMATION

1.1 Packing List

The XenoWorks™ analog microinjector is shipped with the following components.

- | | |
|-------------------------------|-----------------------------|
| 1. Analog Microinjector Drive | 5. Ferrules (6 pieces) |
| 2. Micropipette holder | 6. Spare O-rings (6 pieces) |
| 3. Pressure fittings | 7. Instruction manual |
| 4. 1m tubing (2 pieces) | |

Use the Figure 1-1 to identify the parts listed. If any items are missing or damaged, contact Sutter Instrument immediately.

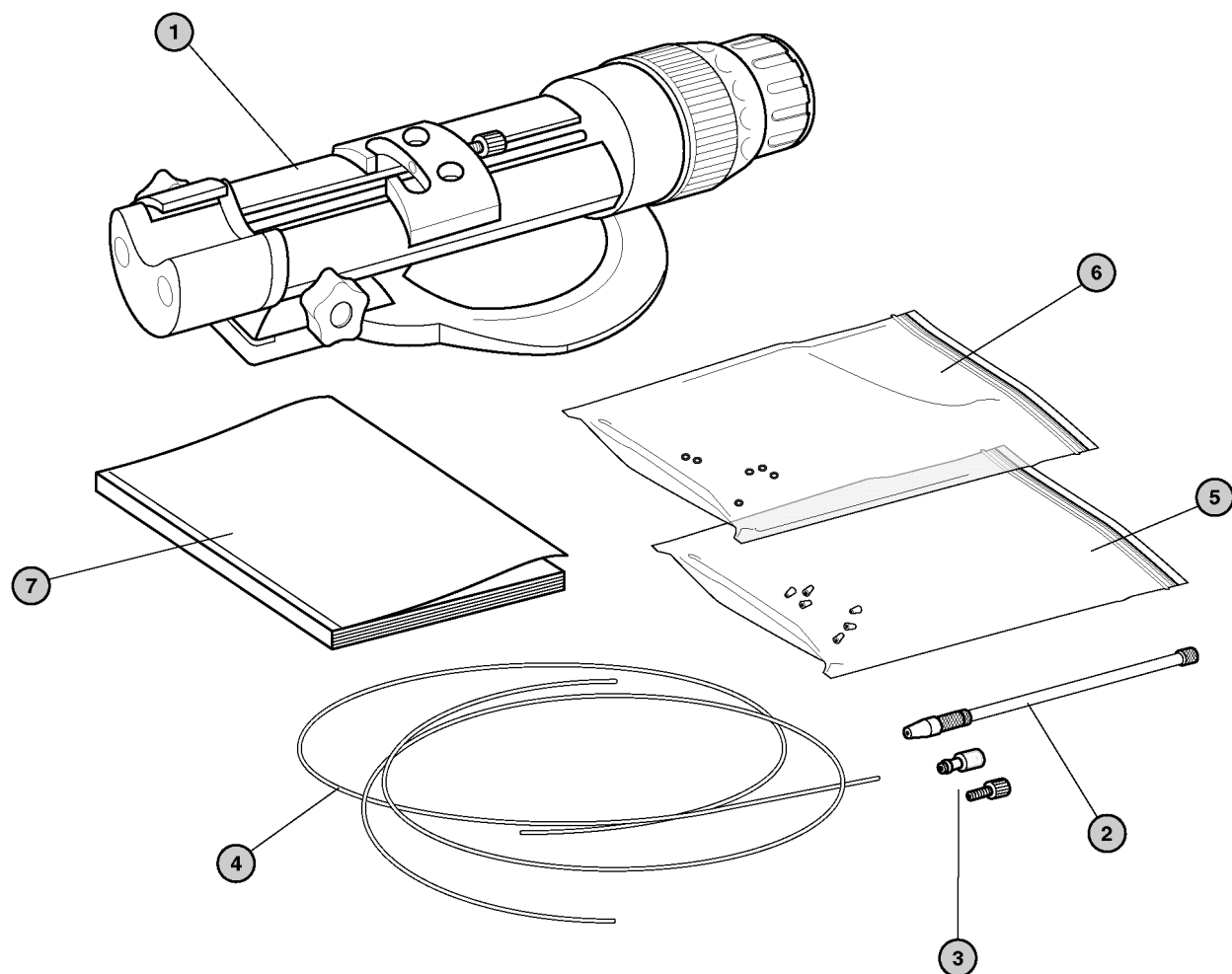

Figure 1-1. Components of the XenoWorks analog microinjector.

NOTE: To operate the Analog Microinjector, an appropriate syringe is also required. A 500-microliter syringe has been supplied and has been shipped along with the Analog Microinjector. Please contact Sutter Instrument immediately if this item cannot be located.

1.2 Controls and Features

The figure below illustrates the XenoWorks Analog Microinjector fully assembled, complete with syringe.

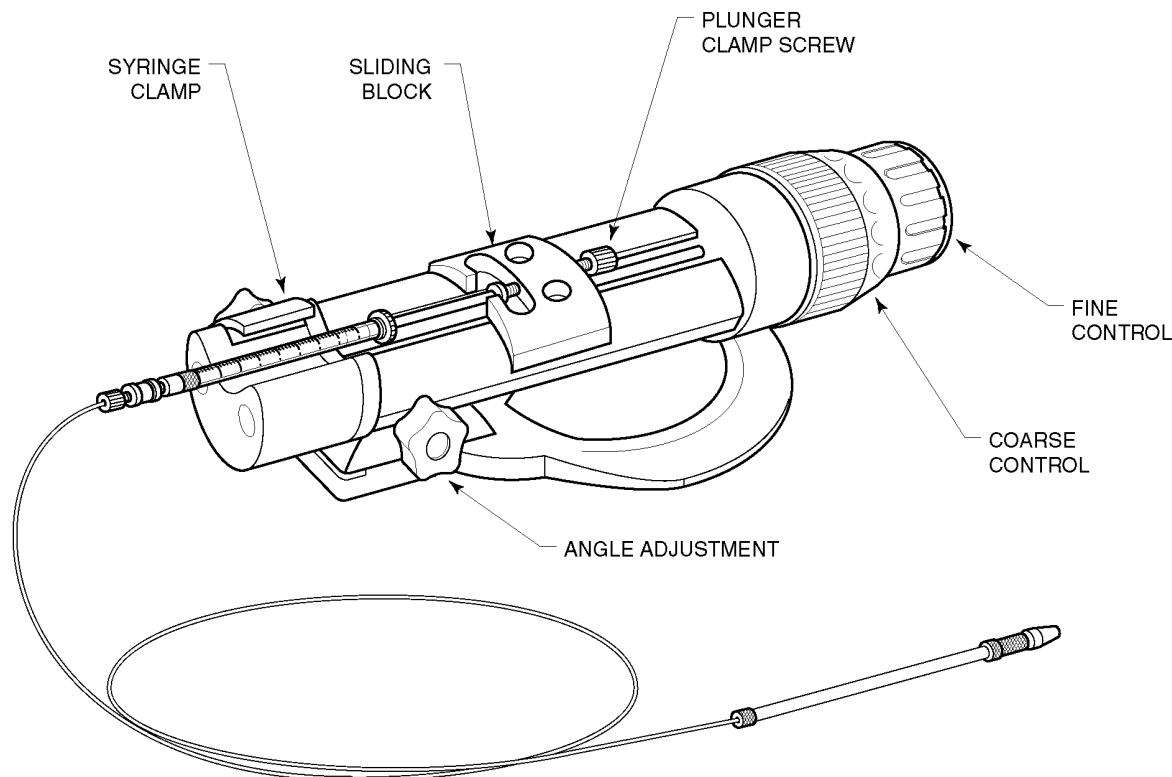

Figure 1-2. Analog microinjector controls and features.

1.2.1 Syringe Clamp

This holds the glass body of the syringe barrel gently and firmly in place. See below for notes on syringe attachment.

1.2.2 Plunger Clamp Screw

This grips the end of the syringe plunger, allowing it to be pushed in and out of the syringe barrel by the movement of the black sliding block.

1.2.3 Sliding Block

The sliding block is moved along the body of the analog microinjector, moving the syringe plunger that it grips, in and out of the syringe barrel. The sliding block is moved by rotation of the micrometer screw (which can be seen running the length of the inside body of the microinjector). The micrometer screw is turned by rotation of the coarse and fine controls.

1.2.4 Coarse and Fine Controls

Turning the coarse and fine controls rotates the micrometer screw that moves the sliding block up and down the body of the microinjector and in turn moves the syringe plunger. Turning either control clockwise moves the syringe plunger into the syringe barrel, pushing out the hydraulic fluid and injecting the contents of any attached micropipette. Conversely, rotation of the controls counter-clockwise pulls the plunger out of the syringe barrel and

creates suction in the attached micropipette. One rotation of the coarse control is equivalent to ten turns of the fine control.

CAUTION: THE CONTROLS SHOULD BE OPERATED INDEPENDENTLY; OPERATING BOTH CONTROLS SIMULTANEOUSLY MAY DAMAGE THE UNIT.

1.2.5 Angle Adjustment

This knob is used to fix the microinjector at an angle appropriate for comfortable use.

1.3 Micropipette Holder

The micropipette holder is attached, via a length of tubing, to the tip of the syringe. The default holder will grip a 1mm diameter capillary micropipette. The figure below shows the micropipette holder disassembled.

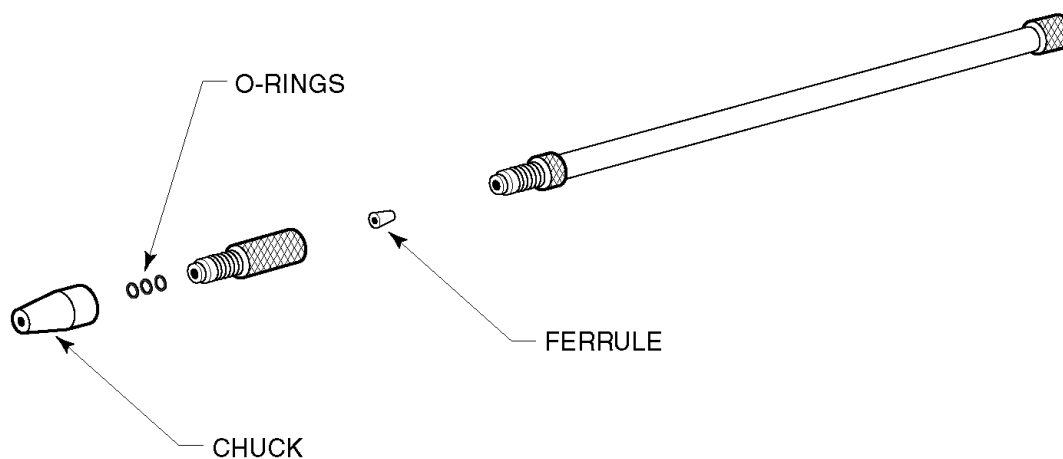

Figure 1-3. Micropipette holder components.

(This page intentionally left blank.)

2. ASSEMBLY AND INSTALLATION

2.1 Installation and Assembly

The following steps describe the installation and assembly of the XenoWorks™ Analog Microinjector.

NOTE: The XenoWorks™ Analog Microinjector is designed so that it can be assembled without the need for tools. Do not use tools to tighten pressure fittings.

1. Unpack the XenoWorks Analog Microinjector drive and place it on a firm flat surface. Ensure that the black sliding block is at approximately $\frac{3}{4}$ of its travel from the back of the injector (the control end).
2. At one end of the tubing, attach the clear Luer connector and the black nut, capturing the clear ferrule in between, as shown below. Take care to ensure that the angle of the ferrule is pointing in the correct direction.

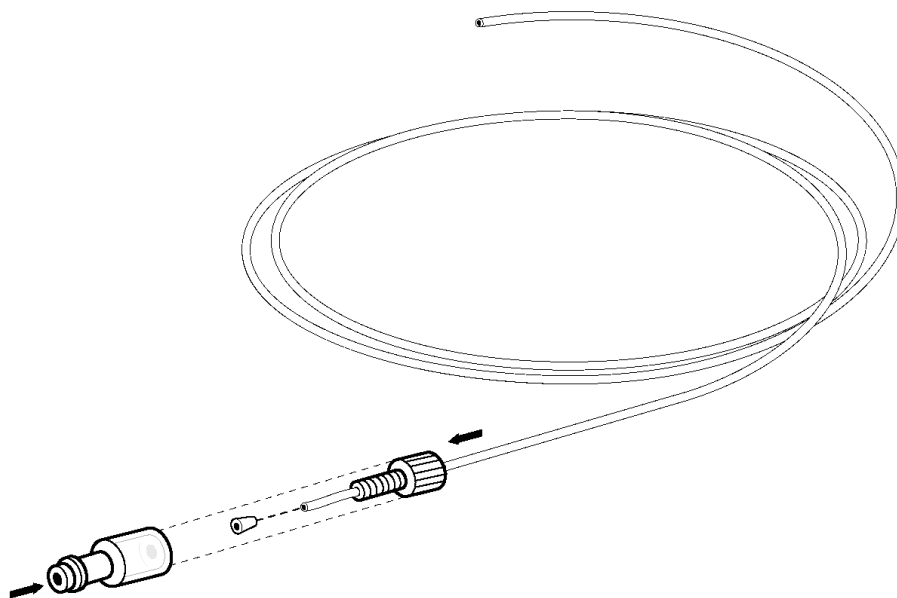

Figure 2-1. Attaching the tubing to the injector.

3. Unpack the syringe and ensure the plunger is pushed all the way in.

NOTE: If you have decided to use the system with air (instead of hydraulic fluid), skip to Step 8.

4. Dip the tip of the syringe into a bottle or dish of the chosen hydraulic fluid, and gently draw the plunger out so that the barrel fills completely with hydraulic fluid. Take care not to draw the plunger up too fast since the fluid may cavitate and form air bubbles.
5. Turn the syringe upright, so that the tip is pointing upwards and allow any air bubbles to float to the top. Gently tap the syringe to facilitate this.
6. Connect the tubing to the tip of the syringe as shown Figure 2-2 and gently and slowly push the plunger so that hydraulic fluid moves to the tip of the tubing.

NOTE: The tubing length supplied contains approximately 450 microliters of fluid. If a syringe with less than 500 microliters volume is being used, a concomitantly shorter piece of tubing must be attached, otherwise the fluid cannot be pushed to the tubing tip. A guide to syringe volumes and appropriate tubing lengths is shown in the table in Figure 2-2, please refer to the Troubleshooting section for more information.

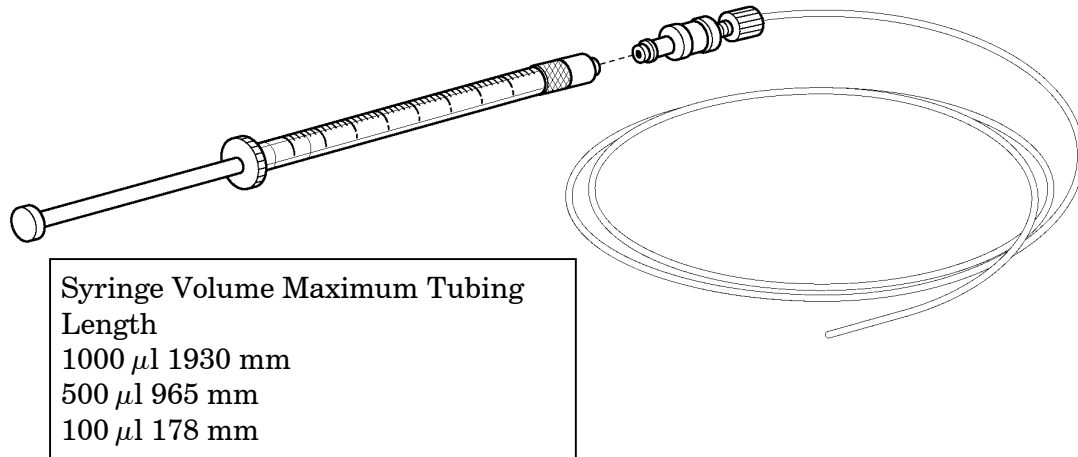

Figure 2-2. Connecting the tubing to the tip of the syringe.

8. Once the hydraulic fluid has been pushed to the very tip of the tubing, dip the tip of the tubing into the bottle or dish of hydraulic fluid and very slowly draw more hydraulic fluid into the tubing until the syringe is approximately $\frac{3}{4}$ full. Again, take particular care not to cavitate the hydraulic fluid or draw up any air bubbles. It may be necessary to repeat Steps 3 - 7 until all bubbles are purged from the syringe and tubing.

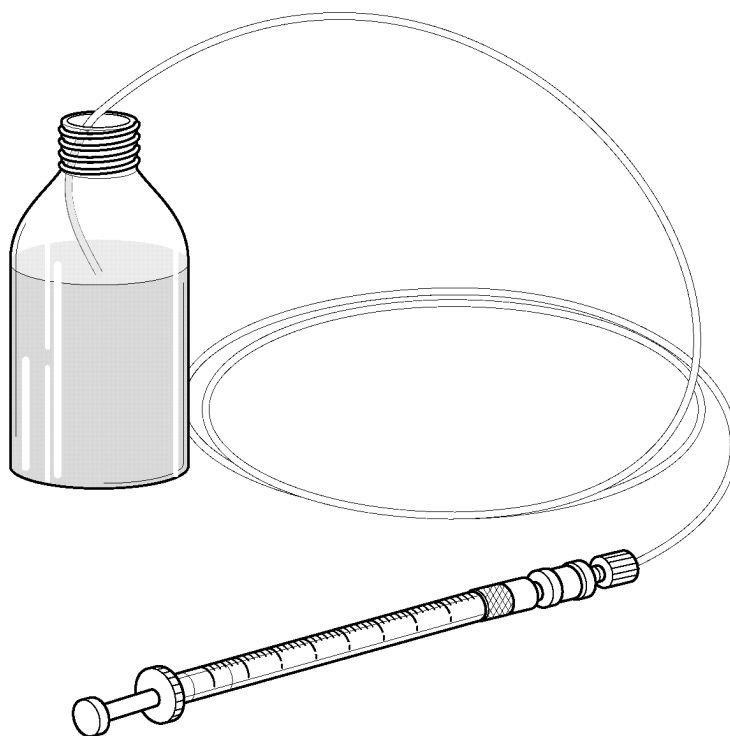

Figure 2-3. Drawing hydraulic fluid into the syringe.

9. Place the syringe into the Analog Microinjector drive, placing the end of the syringe plunger in the sliding block. It may be necessary to use the microinjector's coarse control to reposition the moving block before the plunger will drop into place.
10. With one hand, hold the syringe clamp down on the syringe barrel and tighten the clamp screw until the syringe barrel is held securely. Next, tighten the plunger clamp screw. Take care to tighten the black syringe barrel clamp first before tightening the silver plunger screw. ***CAUTION: To avoid breaking the syringe, clamp only the smooth glass area, and do not over-tighten the clamp screws.***
11. Remove the free end of the tubing from the bottle or dish of hydraulic fluid (if used), wipe it with a clean cloth and thread the tip of the tubing through the rear of the micropipette holder and assemble the micropipette holder as shown below.

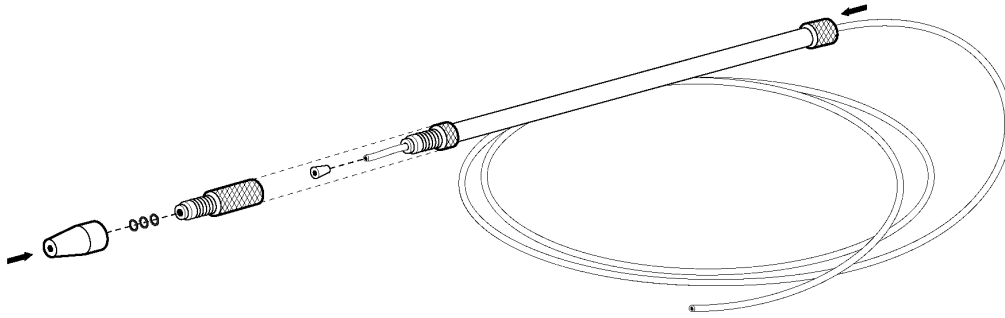

Figure 2-4. Assembling the pipette holder.

12. Adjust the tilt of the microinjector using the angle adjustment knob to achieve a comfortable angle for working and place the unit on the bench top by the micromanipulator.

Your XenoWorks Analog Microinjector is now set up and ready for use.

3. OPERATING INSTRUCTIONS

3.1 General

Typically, the XenoWorks™ Analog Microinjector is used to vary slightly the pressure in the tip of a glass micropipette, thus depositing or aspirating cells or cellular components. The XenoWorks analog microinjector has been designed to work with a number of different syringe volumes, with different tubing lengths and with different hydraulic fluids or simply with air. In this way, the performance of the device can be precisely tuned to the application for which it is used.

The microinjector can employ air, mineral oils or water as the hydraulic fluid, and syringe volumes from 100 to 1000 microliters can be used. A 500 microliter syringe is supplied standard with the device, but 100 and 1000 microliter models are available from Sutter Instrument.

- 100 microliter – part number V001183
- 500 microliter – part number V001185
- 1000 microliter – part number V001186

The XenoWorks Analog Microinjector has two controls: coarse and fine. The coarse control provides ten times the fluid displacement of the fine control. Turn the controls clockwise to inject and counter-clockwise to aspirate.

3.2 Fitting a Micropipette

NOTE: If using air instead of a fluid in the microinjector, skip Step 1.

1. First, remove the clear chuck from the front of the micropipette, and turn the injector's coarse control clockwise to advance the hydraulic fluid to the end of the black aluminum pressure fitting.
2. Replace the clear chuck, but do not tighten it yet.
3. Gently ease a micropipette whose maximum outer diameter does not exceed 1mm into the chuck. The three black O-rings inside the chuck will create a little resistance, which can be overcome by gently turning the micropipette holder body while simultaneously pushing the micropipette in. Do not use excessive force. If the micropipette will not fit snugly in the holder, the O-rings are either damaged or are obstructing the holder and should be replaced.
4. The micropipette should be pushed into the chuck until the hard backstop is felt. At this point, stop pushing and withdraw the micropipette 1 to 2 mm.
5. Gently tighten the chuck so that the O-rings are compressed, and form a seal around the outer diameter of the micropipette. **CAUTION: Do not over-tighten the chuck, or damage may occur to the O-rings.**
6. Turn the coarse control clockwise until the air-fluid meniscus is at the desired point in the micropipette.
7. The newly fitted micropipette and holder can now be attached to the micromanipulator in readiness for microinjection.

(This page intentionally left blank.)

4. MAINTENANCE

4.1 Fitting New O-rings

Routine use will create wear on the three black O-rings located in the tip of the micropipette holder chuck. Occasionally, the O-rings will need to be replaced. To do this, gently remove the old O-rings with an appropriate tool (a bent paper clip, for example). Discard the old O-rings and insert three new ones, taking care to ensure that they are flat against the back of the chuck. The new O-rings can be pushed down inside the chuck by gently screwing the chuck onto the knurled black aluminum pressure fitting. Take care not to damage the chuck during this procedure.

4.2 Troubleshooting

Problem	Cause	Solution
There is poor control by the injector of the material in the micropipette.	1. The black O-rings in the chuck are damaged.	Replace the O-rings.
	2. There is an air bubble in the hydraulic fluid.	Refill the system with hydraulic fluid, taking care not to introduce air bubbles.
	3. The syringe plunger clamp or barrel clamp is not tight.	Tighten the appropriate clamp screws
When drawing hydraulic fluid into the syringe (without tubing attached), air bubbles are forming inside the syringe plunger.	When filling the syringe for the first time, a little air is trapped inside the tip of the syringe, which is drawn into the barrel when the plunger is pulled back.	Slowly draw hydraulic fluid into the barrel, then immediately and rapidly expel it back into the container. Repeat this until a full barrel of hydraulic fluid can be drawn without drawing air bubbles.

(This page intentionally left blank.)

APPENDIX A. LIMITED WARRANTY

- Sutter Instrument Company, a division of Sutter Instrument Corporation, limits the warranty on this instrument to repair or replacement of defective components for one year after the date of shipment, provided the instrument has been operated in accordance with the instructions outlined in the instruction manual.
- Abuse, misuse or unauthorized repairs will void this warranty.
- Limited warranty work will be performed only at the factory, and the cost of shipment both ways is to be borne by the user.
- The limited warranty is as stated above and no implied or inferred liability for direct or consequential damages is intended.

(This page intentionally left blank.)

APPENDIX B. ACCESSORIES AND SPARE PARTS

The following spare parts are available for the XenoWorks Analog Microinjector from Sutter Instrument Company.

V001180	10 μ l Syringe
V001181	25 μ l Syringe
V001182	50 μ l Syringe
V001183	100 μ l Syringe
V001184	250 μ l Syringe
V001185	500 μ l Syringe
V001186	1,000 μ l Syringe
BR-MH	Micropipette holder, includes micropipette holder body, 9 O-rings
BR-AT	Analog tubing kit, includes 2 x 1 m ETFE tubing, Luer fitting, 6 ferrules
BR-OIL	XenoWorks oil for injector

Adapters allowing the use of capillary glass micropipettes with outer diameter greater than 1mm are available upon request.

(This page intentionally left blank.)

APPENDIX C. TECHNICAL SPECIFICATIONS



Coarse/Fine ratio	10:1
Displacement / turn*:	
100- μ l syringes:	1.04 μ l coarse, 0.10 μ l fine
500- μ l syringes:	5.20 μ l coarse, 0.52 μ l fine
1,000- μ l syringes:	10.40 μ l coarse, 1.04 μ l fine
Tubing:	1 m ETFE
Micropipette holder diameter:	4 mm
Micropipette compatibility:	1 mm capillary glass**
Piezo-impact drive compatibility:	Prime Tech, Burleigh
Storage Environment:	
Temperature:	0 – 70°C (32 - 158°F)
Humidity:	0 – 95% (non-condensing)
Operating Environment:	
Temperature:	3.5 – 35°C (38.3 - 95°F)
Humidity:	0 – 80% (non-condensing)
Size (without syringe):	250 mm x 127 mm x 96 mm (9.84" x 5" x 3.79")
Weight (without syringe):	1480 g (3.26 lb (3 lb 4.21 oz))

* Displacements are given for Sutter Instrument-supplied syringes and are approximate. Displacement will vary based on actual syringe used.

** Other micropipette glass diameters can be accommodated upon request.

(This page intentionally left blank.)

INDEX

A	
Assembly and Installation	5
C	
Controls and Features.....	2
Angle adjustment.....	3
Coarse control	3
Fine control	3
Micropipette holder	3
Plunger clamp screw	2
Sliding block.....	2
Syringe clamp.....	2
D	
disclaimer	iii
G	
General Safety Information	iii
I	
Installation and assembly	5
M	
Maintenance.....	11
Fitting new O-rings	
	11
N	
notes	
user.....	20
O	
Operating Instructions.....	9
Fitting a micropipette	9
P	
Product Description	1
S	
Spare Parts.....	15
Specifications	17
T	
technical support	iii
Troubleshooting.....	11
W	
warranty	13

NOTES